



Series
2000

Magnehelic® Differential Pressure Gages

Indicate Positive, Negative or Differential, Accurate within 2%



Scan here
to watch
product video

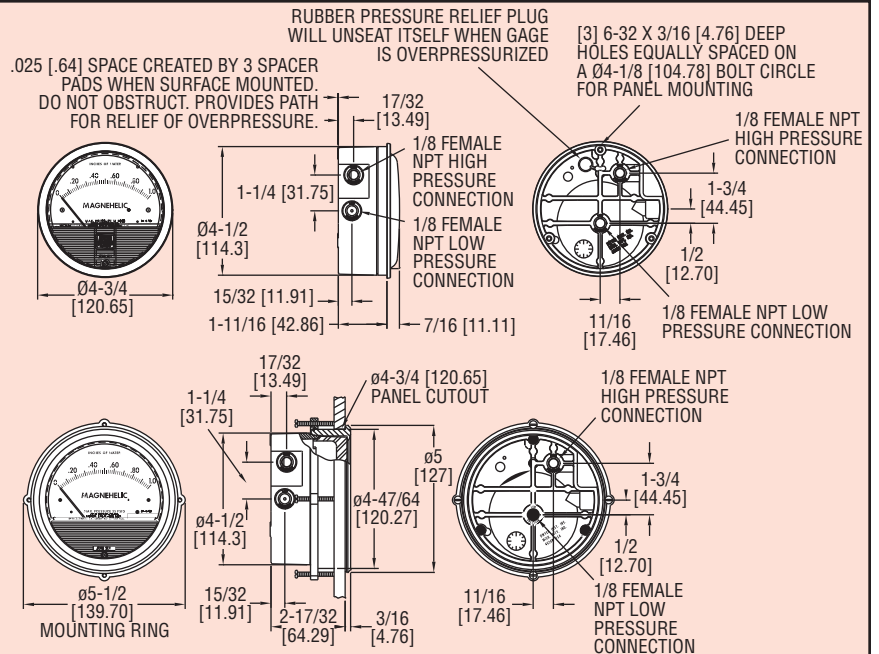

Select the Dwyer® Magnehelic® gage for high accuracy – guaranteed within 2% of full-scale – and for the wide choice of 81 models available to suit your needs precisely. Using Dwyer's simple, frictionless Magnehelic® gage movement, it quickly indicates low air or non-corrosive gas pressures – either positive, negative (vacuum) or differential. The design resists shock, vibration and over-pressures. No manometer fluid to evaporate, freeze or cause toxic or leveling problems. It's inexpensive, too.

The Magnehelic® gage is the industry standard to measure fan and blower pressures, filter resistance, air velocity, furnace draft, pressure drop across orifice plates, liquid levels with bubbler systems and pressures in fluid amplifier or fluidic systems. It also checks gas-air ratio controls and automatic valves, and monitors blood and respiratory pressures in medical care equipment.

MOUNTING

A single case size is used for most models of Magnehelic® gages. They can be flush or surface mounted with standard hardware supplied. Although calibrated for vertical position, many ranges above 1" may be used at any angle by simply re-zeroing. However, for maximum accuracy, they must be calibrated in the same position in which they are used. These characteristics make Magnehelic® gages ideal for both stationary and portable applications. A 4-9/16" hole is required for flush panel mounting. Complete mounting and connection fittings, plus instructions, are furnished with each instrument. Ⓛ

ACCESSORIES



Model A-432 Portable Kit

Combine carrying case with any Magnehelic® gage of standard range, except high pressure connection. Includes 9 ft (2.7 m) of 3/16" ID rubber tubing, standhang bracket and terminal tube with holder.

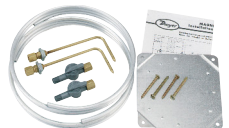

Model A-605 Air Filter Gage Accessory Kit

Adapts any standard Magnehelic® gage for use as an air filter gage. Includes aluminum surface mounting bracket with screws, two 5 ft (1.5 m) lengths of 1/4" aluminum tubing two static pressure tips and two molded plastic vent valves, integral compression fittings on both tips and valves.

A-605B Air Filter Gage Accessory Kit, Air filter kit with two plastic open/close valves, two 4" steel static fins, plastic tubing and mounting flange

Accessory Kit, Air filter kit with two plastic open/close valves, plastic tubing and mounting flange

SPECIFICATIONS

Service: Air and non-combustible, compatible gases (natural gas option available). **Note:** May be used with hydrogen. Order a Buna-N diaphragm. Pressures must be less than 35 psi.

Wetted Materials: Consult factory.

Housing: Die cast aluminum case and bezel, with acrylic cover. Exterior finish is coated gray to withstand 168 hour salt spray corrosion test.

Accuracy: ±2% of FS (±3% on -0, -100 Pa, -125 Pa, 10MM and ±4% on -00, -60 Pa, -6MM ranges), throughout range at 70°F (21.1°C).

Pressure Limits: -20 in Hg to 15 psig (-0.677 to 1.034 bar); MP option: 35 psig (2.41 bar); HP option: 80 psig (5.52 bar).

Overpressure: Relief plug opens at approximately 25 psig (1.72 bar), standard gages only. Ⓛ

Temperature Limits: 20 to 140°F* (-6.67 to 60°C), -20°F (-28°C) with low temperature option.

Size: 4" (101.6 mm) diameter dial face. **Mounting Orientation:** Diaphragm in vertical position. Consult factory for other position orientations.

Process Connections: 1/8" female NPT duplicate high and low pressure taps - one pair side and one pair back. **Weight:** 1 lb 2 oz (510 g), MP & HP 2 lb 2 oz (963 g).

Standard Accessories: Two 1/8" NPT plugs for duplicate pressure taps, two 1/8" pipe thread to rubber tubing adapter, and three flush mounting adapters with screws. (Mounting and snap ring retainer substituted for three adapters in MP & HP gage accessories.)

Agency Approval: RoHS. **Note:** -SP models not RoHS approved.

*For applications with high cycle rate within gage total pressure rating, next higher rating is recommended. See Medium and High pressure options.



Flush, Surface or Pipe Mounted



Enclosure Mounted

Ⓛ See page 7 (Magnehelic® Gage Mounting Accessories)
Ⓛ Over Protection Note: See page 5 (Series 2000)



tetisan



Series
2000

Magnehelic® Gage Models & Ranges

PRESSURE

Differential Pressure Gages

Bezel provides flange for flush mounting in panel.

Clear plastic face is highly resistant to breakage. Provides undistorted viewing of pointer and scale.

Precision litho-printed scale is accurate and easy to read.

Calibrated range spring is flat spring steel. Small amplitude of motion assures consistency and long life. It reacts to pressure on diaphragm. Live length adjustable for calibration.

Red tipped pointer of heat treated aluminum tubing is easy to see. It is rigidly mounted on the helix shaft.

Pointer stops of molded rubber prevent pointer over-travel without damage.

“Wishbone” assembly provides mounting for helix, helix bearings and pointer shaft.

Jeweled bearings are shock-resistant mounted; provide virtually friction-free motion for helix. Motion damped with high viscosity silicone fluid.

Helix is precision made from an alloy of high magnetic permeability. Mounted in jeweled bearings, it turns freely, following the magnetic field to move the pointer across the scale.

Zero adjustment screw is conveniently located in the plastic cover, and is accessible without removing cover. O-ring seal provides pressure tightness.

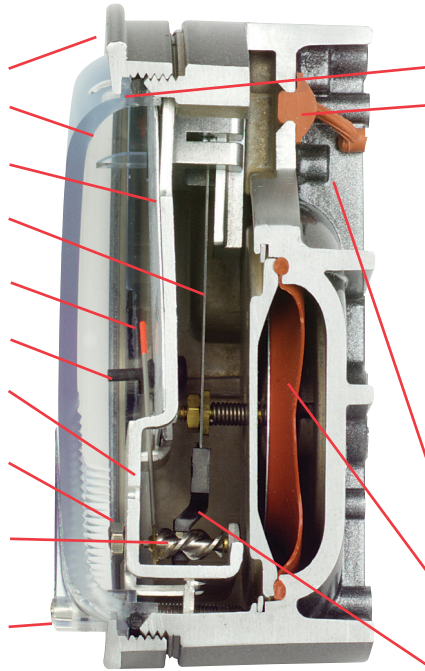

O-ring seal for cover assures pressure integrity of case.

OVERPRESSURE PROTECTION

Blowout plug is comprised of a rubber plug on the rear which functions as a relief valve by unseating and venting the gage interior when over pressure reaches approximately 25 psig (1.7 bar). To provide a free path for pressure relief, there are four spacer pads which maintain 0.023” clearance when gage is surface mounted. Do not obstruct the gap created by these pads.

The blowout plug is not used on models above 180” of water pressure, medium or high pressure models, or on gages which require an elastomer other than silicone for the diaphragm.

The blowout plug should not be used as a system overpressure control. High supply pressures may still cause the gage to fail due to over pressurization, resulting in property damage or serious injury. Good engineering practices should be utilized to prevent your system from exceeding the ratings or any component.

Die cast aluminum case is precision made and iridite-dipped to withstand 168 hour salt spray corrosion test. Exterior finished in baked dark gray hammerloid. One case size is used for all standard pressure options, and for both surface and flush mounting.

Silicone rubber diaphragm with integrally molded O-ring is supported by front and rear plates. It is locked and sealed in position with a sealing plate and retaining ring. Diaphragm motion is restricted to prevent damage due to overpressures.

Samarium Cobalt magnet mounted at one end of range spring rotates helix without mechanical linkages.

Model	Range Inches of Water	Model	Range PSI	Model	Range MM of Water	Model	Range, kPa	Dual Scale Air Velocity Units For use with pitot tube																					
2000-00N†**	.05-0-.2	2201	0-1	2000-6MM†**	0-6	2000-0.5KPA	0-0.5	Model	Range in W.C./ Velocity F.P.M.																				
2000-00†**	0-.25	2202	0-2	2000-10MM†*	0-10	2000-1KPA	0-1			2000-00AV†**	0-.25/300-2000																		
2000-0†*	0-.50	2203	0-3	2000-15MM	0-15	2000-1.5KPA	0-1.5	2000-0AV†*	0-.50/500-2800																				
2001	0-1.0	2204	0-4	2000-25MM	0-25	2000-2KPA	0-2			2001AV	0-1.0/500-4000																		
2002	0-2.0	2205	0-5	2000-30MM	0-30	2000-2.5KPA	0-2.5					2002AV	0-2.0/1000-5600																
2003	0-3.0	2210*	0-10	2000-50MM	0-50	2000-3KPA	0-3							2005AV	0-5.0/2000-8800														
2004	0-4.0	2215*	0-15	2000-80MM	0-80	2000-4KPA	0-4									2010AV	0-10/2000-12500												
2005	0-5.0	2220*	0-20	2000-100MM	0-100	2000-5KPA	0-5											Zero Center Ranges	Model										
2006	0-6.0	2230**	0-30	2000-125MM	0-125	2000-8KPA	0-8													2300-00D†**	Range, in w.c.								
2008	0-8.0			2000-150MM	0-150	2000-10KPA	0-10															2000-0D†*	Range, Pa or kPa						
2010	0-10			2000-200MM	0-200	2000-15KPA	0-15																	2001D	0-1.0				
2012	0-12			2000-250MM	0-250	2000-20KPA	0-20																			2002D	0-2.0		
2015	0-15			2000-300MM	0-300	2000-25KPA	0-25																					2003D	0-3.0
2020	0-20			Zero Center Ranges		2000-30KPA	0-30																						
2025	0-25			2300-6MM†**	3-0-3	Zero Center Ranges		2005D	0-5.0																				
2030	0-30			2300-10MM†*	5-0-5	2300-1KPA	.5-0-.5			2006D	0-6.0																		
2040	0-40			2300-20MM†*	10-0-10	2300-2KPA	1-0-1					2008D	0-8.0																
2050	0-50			Model		2300-2.5KPA	1.25-0-1.25							2010D	0-10														
2060	0-60			Range, Pa		2300-3KPA	1.5-0-1.5									2015D	0-15												
2080	0-80			2000-60NPA†**	10-0-50	Dual Scale English/Metric Models												2020D	0-20										
2100	0-100			2000-60PA†**	0-60	Model	Range, in w.c.													2025D	0-25								
2120	0-120			2000-100PA†*	0-100	2000-00D†**	0-.25															2050D	0-50						
2150	0-150			2000-125PA†*	0-125	2000-0D†*	0-0.5																	2060D	0-60				
2160	0-160			2000-250PA	0-250	2001D	0-1.0																			Zero Center Ranges	Model		
2180*	0-180			2000-300PA	0-300	2002D	0-2.0																					2300-4CM	Range, Pa
2250*	0-250			2000-500PA	0-500	2003D	0-3.0																						
				2000-750PA	0-750	2004D	0-4.0	2300-30CM	2000-0D†*																				
				2000-1000PA	0-1000	2005D	0-5.0			Zero Center Ranges	2001D																		
						2006D	0-6.0					2300-100PA†*	2002D																
						2008D	0-8.0							2300-120PA	2003D														
						2010D	0-10									2300-200PA	2004D												
						2015D	0-15											2300-250PA	2005D										
						2020D	0-20													2300-300PA	2006D								
						2025D	0-25															2300-500PA	2008D						
						2050D	0-50																	2300-1000PA	2010D				
						2060D	0-60																			Zero Center Ranges	Model		
																												2300-60PA†**	Range, Pa
								2300-120PA	50-0-50																				
										2300-200PA	60-0-60																		
												2300-250PA	100-0-100																
														2300-300PA	125-0-125														
																2300-500PA	150-0-150												
																		2300-1000PA	250-0-250										
																				2300-1000PA	500-0-500								
																						2300-1000PA	500-0-500						

VELOCITY AND VOLUMETRIC FLOW UNITS

Scales are available on the Magnehelic® that read in velocity units (FPM, m/s) or volumetric flow units (SCFM, m³/s, m³/h). Stocked velocity units with dual range scales in inches w.c. and feet per minute are shown above. For other ranges contact the factory.

When ordering volumetric flow scales please specify the maximum flow rate and its corresponding pressure. Example: 0.5 in w.c. = 16,000 CFM.

ACCESSORIES

- A-321, Safety Relief Valve
- A-448, 3-piece magnet kit for mounting Magnehelic® gage directly to magnetic surface
- A-135, Rubber gasket for panel mounting
- A-401, Plastic Carry Case

A-310A 3-Way Vent Valves

In applications where pressure is continuous and the Magnehelic® gage is connected by metal or plastic tubing which cannot be easily removed, we suggest using Dwyer A-310A vent valves to connect gage. Pressure can then be removed to check or re-zero the gage.



tetisan



Magnehelic® Gage Options

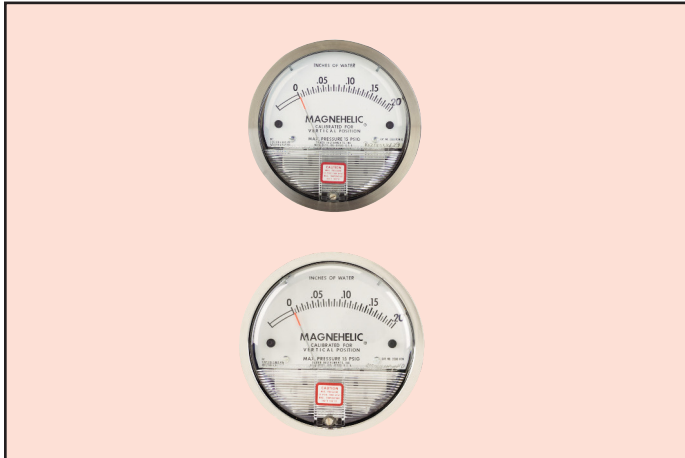
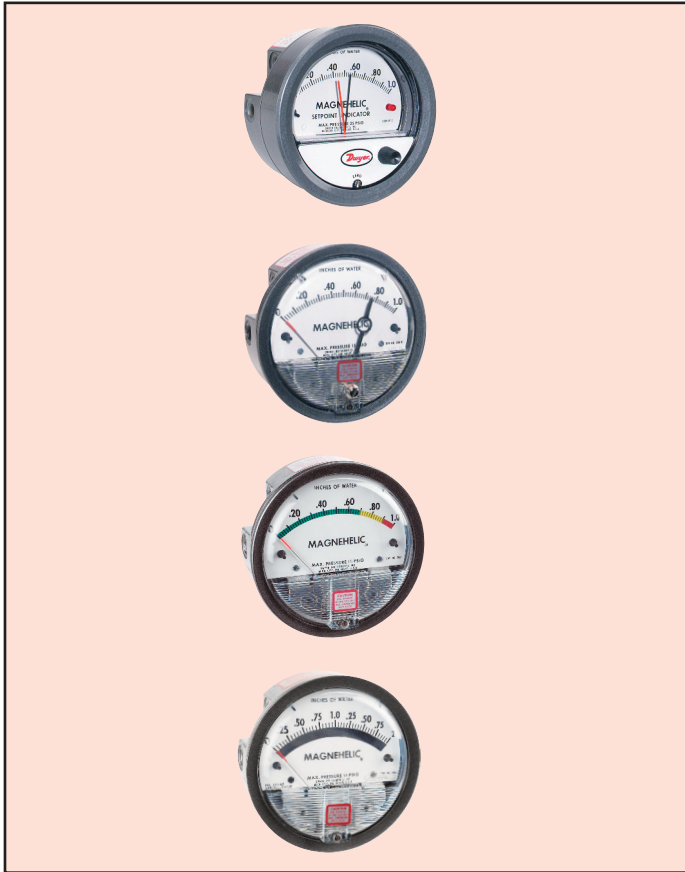

LED Setpoint Indicator

Bright red LED on right scale shows when setpoint is reached. Field adjustable from gage face, unit operates on 12-24 VDC. Setpoint indicator option comes with medium pressure (MP) bezel.

Note: 4-13/16" hole for flush mounting.

To order add suffix -SP

Adjustable Signal Flag

Integral with plastic gage cover. Available for most models except those with medium or high pressure construction. Can be ordered with gage or separate.

To order add suffix -ASF

Transparent Overlays

Furnished in red, yellow, or green to highlight and emphasize critical pressures.

To order add suffix -R (Red)

To order add suffix -Y (Yellow)

To order add suffix -G (Green)

Mirrored Scale Overlay

A Mirrored Scale Overlay is also available to assist in reducing parallax error.

To order add suffix -M

MODELS FOR HIGH STATE PRESSURE APPLICATIONS

Medium Pressure Option: for pressures to 35 psig.

To order add suffix -MP

High Pressure Option: for pressures to 80 psig.

To order add suffix -HP

OPTIONAL BEZELS

Stainless Steel Bezel Option:

304 Stainless Steel Electro polished Ra 16 finished bezel for the Magnehelic® is now available.

To order add suffix -SB

Chrome Bezel Option:

A Chrome Plated Aluminum Bezel is now available on the Magnehelic® gage for an aesthetically pleasing finish when mounting on metal surfaces such as control panels.

To order add suffix -CB

OPTIONS — To order, add suffix: I.E. 2001-ASF

LT, Low Temperatures to -20°F (-28°C)

NIST, NIST traceable calibration certificate

FC, factory calibration certificate



tetisan



Magnehelic® Gage Mounting Accessories

MOUNTING. A single case size is used for most models of Magnehelic® gages. They can be flush or surface mounted with standard hardware supplied. Complete mounting and connection fittings plus instructions are furnished with each instrument. A 4-9/16" hole is required for flush panel mounting.

Flush mounting is easily accomplished with the new A-300 Flush Mounting bracket. This bracket provides a solution to quickly and conveniently flush mount the Magnehelic®. The A-300 is ideal for mounting the Magnehelic® on control panel doors.

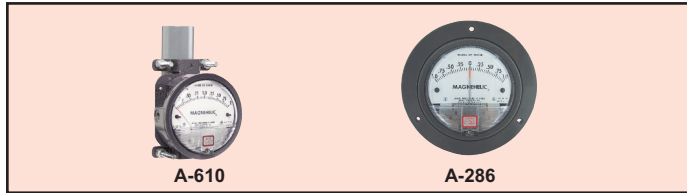

A-610

A-286

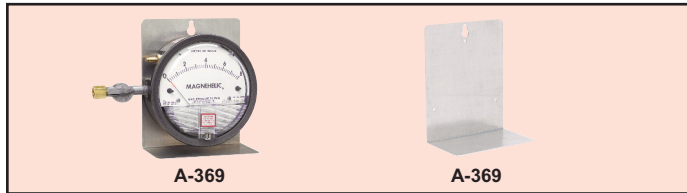

A-369

A-369

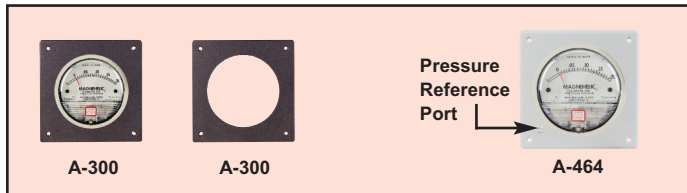

A-300

A-300

Pressure Reference Port

A-464

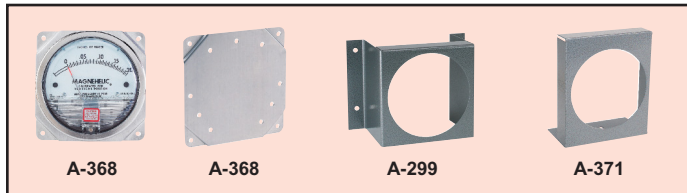

A-368

A-368

A-299

A-371

The A-368 is a simple bracket for quickly surface mounting the Magnehelic® gage. After securing the Magnehelic® to the A-368 bracket, mount the bracket on any flat surface.

The A-369 allows the Magnehelic® to be easily carried to locations where pressure readings need to be taken. The A-369 can stand on its own or hang on a nail or hook.

PIPE

A-610, Pipe Mounting Kit for installing on 1-1/4" to 2" horizontal or vertical pipe

PANEL

A-286, Magnehelic® Gage Panel Mounting Flange

PORTABLE

A-369, Stand-Hang Bracket, aluminum, for Magnehelic® gage

FLUSH

A-300, Flush Mounting Bracket

A-464, Flush Mount Kit for Magnehelic® Gages

SURFACE

A-368, Surface Mounting Plate, aluminum, for Magnehelic® gage

A-299, Mounting Bracket, flush mount for Magnehelic® Gage. Bracket is then surface mounted. Steel with gray hammerloid epoxy finish

A-371, Surface Mounting Bracket. Use with medium pressure (-MP) or high pressure (-HP) models only



Series A-320

Instrument Enclosure

Protects Various Instruments

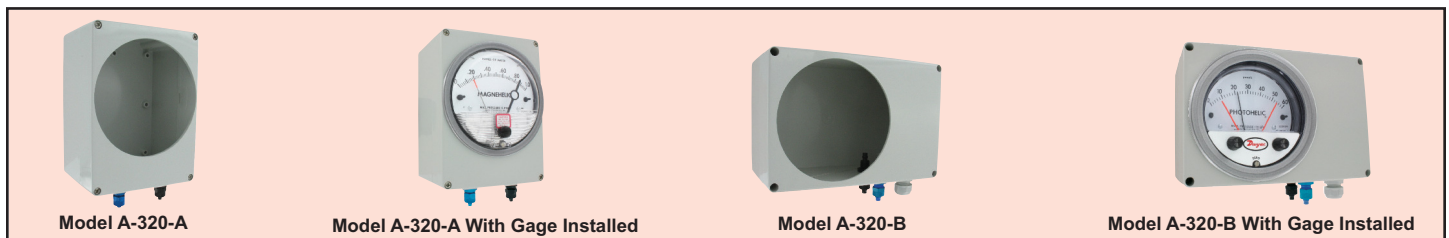

Series A-320 Instrument Enclosure protects instruments in all applications. The A-320-A fits standard Magnehelic® size instruments (4-9/16" diameter) and the A-320-B fits standard 3000MR Photohelic® switch/gage size instruments (4-13/16" diameter). Both models include silicone tubing, gage barbs and mounting hardware.

SPECIFICATIONS

Housing: ABS.

Process Connections: Anodized aluminum.

Enclosure Rating: NEMA 1 (IP10).

Note: Check instruments rating.

Weight: Model A-320-A: 11.29 oz (320 g); A-320-B: 16.23 oz (420 g).

Gage Size Opening: A-320-A: 4-9/16 in (115.89 mm); A-320-B: 4-13/16 in (122.24 mm).

Model	Compatible Instruments
A-320-A	Series 2000 Magnehelic® Gages, DM-1000 Digital Differential Pressure Gages, DM-2000 Differential Pressure Transmitter 3000MR Photohelic® Switch/Gage, Series 605 Magnehelic®
A-320-B	Differential Pressure Transmitter, DH3 Digihelic® Pressure Series 2000 Magnehelic® Gage with medium and low options



tetisan



Series
AT2
2000

ATEX Approved Series 2000 Magnehelic® Differential Pressure Gauge

Magnehelic® Gauge in Flame-Proof ATEX Enclosure

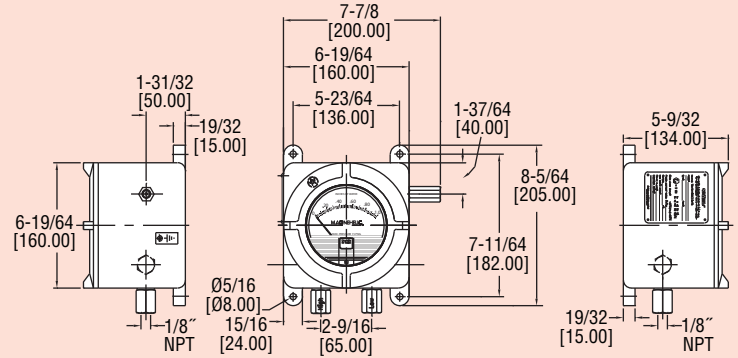

The popular **Magnehelic® Differential Pressure Gauge** is now available in a flame-proof ATEX enclosure with the new ATEX approved **AT22000 Series**. This gage can indicate positive, negative or differential pressures and is accurate within 2%. The Magnehelic® gage is the industry standard to measure fan and blower pressures, filter resistance, air velocity, furnace draft, pressure drop across orifice plates, liquid levels with bubbler systems and pressures in fluid amplifier or fluidic systems. Optional gage construction is available for use to either 35 psig (2.42 bar) or 80 psig (5.51 bar). Flame-proof ATEX enclosures are available in aluminum and include a glass window for viewing process pressures status on gage face.

Important notes for installation:

- Cables must be fitted through 1/2" NPT cable gland or ATEX conduit (not supplied with instrument).
- Make sure after cabling to close tight cover and cable gland, in order to keep IP66 rating (IP65 with option OPV, overpressure relief valve).
- Open cover only after de-energizing instrument.
- **Attention:** Check local safety rules and warnings on unit and manual for a correct use of the instrument in hazardous area.

RANGE CHART

Model	Range in w.c.
2000-00N	.05 to 0 to .2
2000-00	0 to .25
2000-0	0 to .50
2001	0 to 1.0
2002	0 to 2.0
2003	0 to 3.0
2004	0 to 4.0
2005	0 to 5.0
2006	0 to 6.0
2008	0 to 8.0
2010	0 to 10
2012	0 to 12
2015	0 to 15
2020	0 to 20
2025	0 to 25
2030	0 to 30
2040	0 to 40
2050	0 to 50
2060	0 to 60
2080	0 to 80
2100	0 to 100
2120	0 to 120
2150	0 to 150

SPECIFICATIONS

- Service:** Air and non-combustible, compatible gases.
- Wetted Materials:** Consult factory.
- Magnehelic® Housing:** Die cast aluminum case & bezel with acrylic cover; Exterior finish is coated gray to withstand 168 hour salt spray corrosion test.
- Housing Material:** Aluminum.
- Finishing:** Texture epoxy coat RAL7038.
- Accuracy:** ±2% of FS (±3% on -0, -100 Pa, -10 mm and ±4% on -00, -60 Pa, -6 mm ranges), throughout range at 70°F (21.1°C).
- Pressure Limits:** -20 in Hg to 15 psig (-0.677 bar to 1.034 bar); MP option; 35 psig (2.41 bar), HP option; 80 psig (5.52 bar).
- Overpressure:** Relief plug opens at approximately 25 psig (1.72 bar), standard gages only.
- Temperature Limits:** 20 to 140°F (-6.67 to 60°C); Low temperature option: -20°F (-28.8°C); Case: -58 to 140°F (-50 to 60°C) (**Note:** Product temperature limits are less than case limits).
- Mounting Orientation:** Diaphragm in vertical position.
- Enclosure Rating:** IP66. IP65 with option OPV, overpressure relief valve.
- Process Connections:** 1/8" NPT female brass (SS optional). In presence of acetylene it is necessary to use SS.
- Weight:** 8.6 lb (3.9 kg).
- ATEX Approved Product from Comhas with ECN:** NEMKO 10ATEX1096.
- Agency Approvals:** CE 0470 Ex II 2 GD Ex d IIC Gb T6; -50°C ≤ Ta ≤ +60°C Ex tb IIIC Db T 85°C.

Example	AT2	2001	X	X	A	O	1	X	T2	AT22001-XX-A01XT2
Housing	AT2									ATEX Approved Series 2000 Magnehelic® Differential Pressure Gauge
Range		2XXX								Specify range by using Magnehelic® model number. See Ranger Chart
Pressure Rating			-X							Standard from -20 in Hg to 15 psig static pressure
			-MP							Medium pressure-max. static 35 psig
			-HP							High pressure-max. static 80 psig
Temperature Rating				X						Standard temperature limits -6.67 to 60°C
				LT						Low temperature limit to -28.8°C
Housing Material					-A					Aluminum
Cover						O				Glass cover
Process Connection							1			1/8" NPT female brass ports
							2			1/8" NPT female SS ports
Overpressure Plug							X	OPV		Standard without overpressure relief valve
										Overpressure relief valve
										Material same as ports
Tag									T2	SS information label

Over Protection Note: See page 5 (Series 2000)



tetisan